

“A blueprint for success”

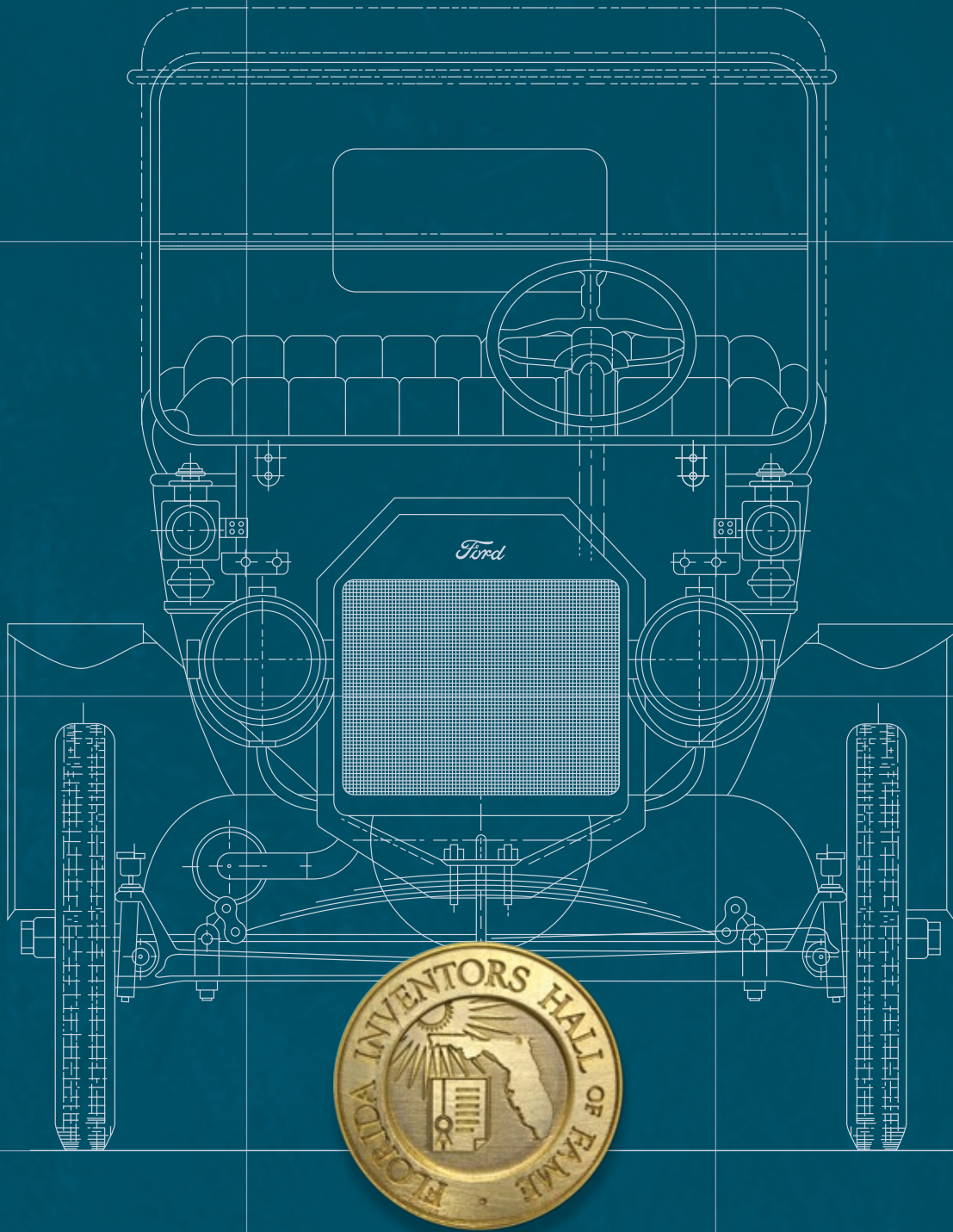

**FLORIDA INVENTORS HALL OF FAME
2ND ANNUAL INDUCTION CEREMONY & GALA**

**FRIDAY, OCTOBER 2, 2015
INTERCONTINENTAL HOTEL**

4860 WEST KENNEDY BOULEVARD • TAMPA, FLORIDA



United States Patent and Trademark Office

Office of the Commissioner for Patents

September 9, 2015

Dr. Paul R. Sanberg
Florida Inventors Hall of Fame
3702 Spectrum Boulevard, Suite 165
Tampa, Florida 33612

Dear Dr. Sanberg:

On behalf of the United States Patent and Trademark Office (USPTO), congratulations to the Florida Inventors Hall of Fame (FIHF), and to you and your fellow 2015 inductees. We are pleased that our Deputy Commissioner for Patent Quality, Valencia Martin Wallace, will participate in the ceremony Oct. 2 to recognize the seven Floridians being inducted, and their significant inventive contributions to society.

The FIHF encourages innovation by celebrating and honoring the remarkable achievements of inventors who have improved the quality of life for Florida's citizens and our nation.

We value the ongoing efforts of the Hall of Fame as we share a common goal to advance and encourage innovation in the U.S., and we look forward to continuing our cooperation in the years ahead.

Again, congratulations to you and the 2015 inductees, and all the best to the Hall of Fame for its continued success.

Sincerely,

A handwritten signature in blue ink, appearing to read "Andrew Hirshfeld".

Andrew Hirshfeld
Commissioner for Patents
United States Patent and Trademark Office

P.O. Box 1450, Alexandria, VA 22313-1450 • www.uspto.gov



United States Senate

WASHINGTON, DC 20510-0905

BILL NELSON
FLORIDA

October 2, 2015

Florida Inventors Hall of Fame
3702 Spectrum Boulevard, Suite 165
Tampa, Florida 33612

Dear Friends:

I would like to offer my congratulations to the Florida Inventors Hall of Fame in recognition of your 2nd Annual Induction Ceremony and Gala, being held in Tampa.

The innovation of its citizens is the backbone of the United States' economic and social success. By supporting a culture of innovation, the Florida Inventors Hall of Fame encourages entrepreneurship in America and inspires new generations of inventors.

I congratulate the 2015 inductees and wish the Florida Inventors Hall of Fame continued success.

Sincerely,

Bill Nelson

KATHY CASTOR
14TH DISTRICT, FLORIDA

COMMITTEE ON
ENERGY AND COMMERCE
SUBCOMMITTEE ON HEALTH
*SUBCOMMITTEE ON
ENERGY AND POWER*
*SUBCOMMITTEE ON
OVERSIGHT AND INVESTIGATIONS*
COMMITTEE ON THE BUDGET
REGIONAL WHIP



Congress of the United States
House of Representatives
Washington, DC 20515-0914

WASHINGTON OFFICE:
205 CANNON BUILDING
WASHINGTON, DC 20515
(202) 225-3376

DISTRICT OFFICE:
4144 NORTH ARMENIA AVENUE
SUITE 300
TAMPA, FL 33607
(813) 871-2817
www.castor.house.gov

October 2, 2015

Dear Dr. Sanberg,

It is with great pleasure that I extend my congratulations to you on your recognition by the Florida Inventors Hall of Fame at its second Annual Induction Ceremony and Gala.

As the founder and president of the National Academy of Inventors and the Senior Vice President for Research, Innovation and Economic Development, you have worked diligently on behalf of science and innovation in our community. Through the creation of the Florida Inventors Hall of Fame, you have committed yourself to honoring inventors like yourself, whose scientific accomplishments have improved the quality of life for people in Florida, and throughout the nation.

Organizations such as the Florida Inventors Hall of Fame strengthen the culture of innovation in Florida and our nation. By recognizing scientific discovery, the Hall of Fame supports the creativity that fuels innovation and drives economic growth throughout the United States. The Florida Inventors Hall of Fame is essential in supporting and recognizing the innovative work that has been achieved by Floridian scientists and inventors, and it is a crucial organization in pioneering economic, intellectual and innovative expansion within our community.

I am pleased to extend best wishes to the Florida Inventors Hall of Fame and applaud your commitment to honoring outstanding inventors whose scientific work has made an impact on society. On behalf of the constituents of the Fourteenth Congressional District of Florida, I once again congratulate you and wish you continued success.

Sincerely,

A handwritten signature in blue ink that reads "Kathy Castor".

Kathy Castor
United States Representative
Florida, District 14

PRINTED ON RECYCLED PAPER

Florida Senate Resolution

By Senator Brandes

A resolution recognizing the inaugural year of the Florida Inventors Hall of Fame,
located at the University of South Florida in Tampa.

WHEREAS, Florida is a state where innovation, research, and discovery thrive and where great American inventors, such as Thomas Edison, have lived and worked, and

WHEREAS, the Florida Inventors Hall of Fame endeavors to encourage individuals of all ages and backgrounds to strive toward the betterment of Florida and society through continuous, groundbreaking innovation, and

WHEREAS, the Florida Inventors Hall of Fame is located at the University of South Florida in order to honor and celebrate the inventors from this state whose achievements have advanced the quality of life of all Americans, and

WHEREAS, the Florida Inventors Hall of Fame will be one of only seven state inventors halls of fame in the nation which will recognize the best and brightest inventors from their respective states, and

WHEREAS, the Florida Inventors Hall of Fame is led by an advisory board consisting of exceptional individuals from the private and public sectors and academia, and

WHEREAS, the inductees to the Florida Inventors Hall of Fame will be chosen by a selection committee composed of equally distinguished members, and

WHEREAS, the inaugural class of inventors inducted to the Florida Inventors Hall of Fame will be recognized in September 2014, NOW, THEREFORE,

Be It Resolved by the Senate of the State of Florida:

That the Florida Inventors Hall of Fame is recognized on the occasion of its inaugural year for its commitment to honoring inventors and celebrating innovation, discovery, and excellence in this state and that the University of South Florida is commended for founding this institution.

BE IT FURTHER RESOLVED that a copy of this resolution be provided to the Florida Inventors Hall of Fame for display as recognition of the Senate's support of innovation in Florida.



This is a true and correct copy
of Senate Resolution No. 1756,
adopted by the Florida Senate
on April 30, 2014.



Dan Gaetz
President of the Senate

ATTEST:



Debbie Brown
Secretary of the Senate



Congressional Record

PROCEEDINGS AND DEBATES OF THE 114th CONGRESS, FIRST SESSION

House of Representatives

HON. GUS M. BILIRAKIS OF FLORIDA

Extension of Remarks

Honoring Inductees of the Florida Inventors Hall of Fame

Tuesday, September 22, 2015

MR. BILIRAKIS. Mr. Speaker, I rise today to honor the 13 inventors who have been recognized as the Inductees of the Florida Inventors Hall of Fame since its founding. In order to be named as an Inductee, these men and women were nominated by their peers and have undergone the scrutiny of the Florida Inventors Hall of Fame Selection Committee. Each of their innovations is deemed to have made a significant impact on quality of life, economic development, and welfare of society for the citizens of Florida and the United States.

The Florida Inventors Hall of Fame was founded in 2013 by Paul R. Sanberg, Senior Vice President for Research, Innovation and Economic Development, and Judy Genshaft, President, at the University of South Florida. It was recognized by the Florida Senate with Senate Resolution 1756, adopted at the request of Florida Senator Jeff Brandes (22nd district), on April 30, 2014. By commending the incredible scientific work that has been, and continues to be, accomplished in Florida and by its citizens, the Florida Inventors Hall of Fame's mission is to encourage individuals of all ages and backgrounds to strive toward the betterment of Florida and society through continuous, groundbreaking innovation.

Nomination to the Florida Inventors Hall of Fame is open to all Florida inventors (living or dead) who are, or who have been, residents of Florida and whose connection to the State has informed their inventive work. The nominee must

be a named inventor on a patent issued by the United States Patent and Trademark Office. The impact of the inventor and his or her invention should be significant to society as a whole, and the invention should have been commercialized, utilized, or led to important innovations.

The 2014 Inductees of the Florida Inventors Hall of Fame are: Thomas Edison (1847-1931), the most prolific inventor in U.S. history and longtime resident of Fort Myers; Robert Cade (1927-2007), University of Florida professor, who developed the hydrating sports drink Gatorade, Gainesville; William Glenn (1926-2013), Florida Atlantic University professor, who invented the high-definition camera for NASA, Boca Raton; John Gorrie (1803-1855), physician and the father of refrigeration and air conditioning, Apalachicola; Shyam Mohapatra, University of South Florida professor and pioneer of applied biomedical nanotechnology, Tampa; and Shin-Tson Wu, University of Central Florida professor, whose liquid crystal research has impacted display technology worldwide, Orlando.

The 2015 Inductees of the Florida Inventors Hall of Fame are: Henry Ford (1863-1947), automotive technology pioneer and Fort Myers resident, who advanced industrial manufacturing and contributed to experimental botanical research; Robert Howard Grubbs, University of Florida graduate, professor at the California Institute of Technology, and recipient of the 2005

Nobel Prize in Chemistry, whose contributions led to new materials in medicine and plastics, Gainesville; Robert Holton, Florida State University professor, who invented the chemical synthesis of Taxol, a widely utilized and highly effective anti-cancer drug, Tallahassee; Jerry Pratt, scientist at the Florida Institute for Human and Machine Cognition, for his revolutionary work in walking robotics, Pensacola; Paul R. Sanberg, professor, and Senior Vice President for Research, Innovation and Economic Development at the University of South Florida, for discovery of novel approaches to drug and cell therapies to treat stroke, brain injuries and diseases, and for founding the National Academy of Inventors, Tampa; Nan-Yao Su, University of Florida professor, who invented Sentricon®, which revolutionized termite control, Gainesville and Fort Lauderdale; and Janet Yamamoto, University of Florida professor, who discovered the deadly feline immunodeficiency virus (FIV), created the FIV vaccine, and furthered research on HIV, Gainesville.

The contributions made to society through innovation and invention are significant and life changing. I commend these individuals and the organizations and institutions that have supported them for the work they have done to benefit the world in which we live. In contemplating the work of these inventors, may future generations be encouraged to strive to emulate these honorees and their dedication to the ideal of innovation.



Welcome to the 2nd Annual Induction Ceremony and Gala of the Florida Inventors Hall of Fame. We are honored to have you with us this evening.

The Florida Inventors Hall of Fame was founded in 2013 to honor and celebrate those inventors whose achievements have advanced the quality of life for Floridians, our state, and our nation. The Florida Inventors Hall of Fame encourages individuals of all ages and backgrounds to strive toward the betterment of Florida and society through continuous, groundbreaking innovation. By commending the incredible scientific work that has been and is being accomplished in the State of Florida, our state will increase interest, funding, and further growth of our innovation sector.

The Florida Inventors Hall of Fame was recognized on April 30, 2014, with a resolution passed by the Florida Senate to honor outstanding Florida inventors. The resolution, adopted at the request of Senator Jeff Brandes, recognizes the Florida Inventors Hall of Fame “for its commitment to honoring inventors and celebrating innovation, discovery, and excellence in this state.”

Nomination to the Florida Inventors Hall of Fame is open to all Florida inventors (living or dead) who are or have been residents of Florida and whose connection to Florida has informed their inventive work. The nominee must be a named inventor on a patent issued by the United States Patent and Trademark Office. The impact of the inventor and his or her invention(s) should be significant to society as a whole and should have been commercialized, utilized, or have led to important innovations.

Inductees are selected annually through a nomination process open to all inventors in the State of Florida. The nominations are reviewed by our Selection Committee, which I had the honor to chair this year. The committee comprises distinguished experts in relevant fields of innovation throughout the state. Nominees elected to the Hall of Fame are inducted at our annual gala, where their achievements are honored and their influence on society acknowledged and celebrated.

It is a privilege to serve with the other members of our Advisory Board, an outstanding and diverse group of leaders and inventors representing public corporations, private businesses, research universities, nonprofit institutes, governmental agencies, and other organizations. We appreciate their guidance and support.

On behalf of the FIHF Advisory Board, we thank President Judy Genshaft, Dr. Paul Sanberg, and the University of South Florida for their vision and support in founding and hosting the Florida Inventors Hall of Fame. And finally, we particularly thank our valued sponsors for their support of the Florida Inventors Hall of Fame and for helping to make this evening possible.

Randy E. Berridge
Florida Inventors Hall of Fame Advisory Board and
Chair of the 2015 Selection Committee
President, Florida High Tech Corridor Council

TONIGHT'S PROGRAM

MASTER OF CEREMONIES

Bill Green

OPENING REMARKS

Randy E. Berridge
Chair, Florida Inventors Hall of Fame 2015 Selection Committee
President, Florida High Tech Corridor Council

Jesse Panuccio
Executive Director
Florida Department of Economic Opportunity

President Judy Genshaft
University of South Florida System

Valencia Martin Wallace
Deputy Commissioner for Patent Quality
United States Patent and Trademark Office

INDUCTION CEREMONY

Deputy Commissioner Wallace
Mr. Berridge

• INDUCTEES •

HENRY FORD (1863-1947)

Automotive technology pioneer and Fort Myers resident who advanced industrial manufacturing and contributed to experimental botanical research

*Accepting on behalf of Henry Ford: Ms. Chris Pendleton,
President/CEO, Edison & Ford Winter Estates, Inc., Fort Myers*

ROBERT HOWARD GRUBBS

Professor and researcher at the California Institute of Technology and recipient of the 2005 Nobel Prize in Chemistry whose contributions led to new materials in medicine and plastics

University of Florida graduate, Gainesville
Introduction by Morteza Gharib, Vice Provost, Caltech

ROBERT HOLTON

Professor and researcher who invented the chemical synthesis of Taxol,
a widely utilized and highly effective anti-cancer drug
Florida State University, Tallahassee

Accepting on behalf of Robert Holton: Dr. Gary Ostrander, Vice President for Research, FSU

JERRY PRATT

Scientist at the Florida Institute for Human & Machine Cognition for his revolutionary work in walking robotics
Pensacola

PAUL R. SANBERG

Distinguished University Professor and Senior Vice President for Research, Innovation & Economic Development,
for discovery of novel approaches to drug and cell therapies to treat stroke and brain injuries and diseases
and for founding the National Academy of Inventors

University of South Florida, Tampa

NAN-YAO SU

Distinguished Professor of Entomology who invented Sentricon[®],
which revolutionized termite control
University of Florida, Gainesville and Fort Lauderdale

JANET YAMAMOTO

Professor and researcher who discovered the deadly feline immunodeficiency virus (FIV),
created the FIV vaccine, and furthered research on HIV
University of Florida, Gainesville

SPEAKERS



Bill Green
Show Host, HSN

Bill Green was born in Miami and, for the past 21 years, has been a Television Show Host and “face” at St. Petersburg-based HSN (Home Shopping Network), the World’s Pioneer of Electronic Retailing. Green is one of a select few male “multi-category” Show Hosts in television retail who presents almost every category of merchandise offered by the network into 96,000,000 homes. He has worked with top celebrities and has a unique, entertaining style and “down-to-earth” personality which connects with viewers and keeps them coming back for more. Widely acknowledged as one of the most dynamic, energetic and successful on-air hosts for his ability to convey the value of a product to a customer, Green has also been a finalist judge for the USF Young Innovator Competition for the past four years. He is currently hosting a new fixed programming jewelry show on HSN every Tuesday evening from 6-8 p.m. called “Be Jeweled with Bill and Connie.”



Randy E. Berridge, President
Florida High Tech Corridor Council
Chair, Florida Inventors Hall of Fame 2015 Selection Committee

Randy Berridge has held the position of president of the Florida High Tech Corridor Council since its formation in 1996. He also currently serves as president of the Berridge Consulting Group, Inc., and advisory board member of SunTrust Bank, N.A. Previously, he held several management positions with AT&T Corporation including chair of the Central Florida AT&T Management Council; district manager of public relations for the Florida division; manager of legal and divestiture planning; and coordinating supervisor of budgets, forecasts, planning, human resources, and manufacturing. He currently serves on the board of the Tampa Bay Partnership, the Foundation for Florida’s College System and as an Emeritus Member of the board of directors of the Astronauts Memorial Foundation. He is chair of the 2015 Selection Committee for the Florida Inventors Hall of Fame and serves on its Advisory Board and is an alumnus of Leadership Orlando and Leadership Florida.



President Judy Genshaft
University of South Florida System

Dr. Judy Genshaft serves as President of the University of South Florida System. USF is a high-impact, global research university dedicated to student success and one of the nation’s largest and most comprehensive metropolitan research universities. USF is a Top 50 research university among both public and private institutions nationwide in total research expenditures, according to the National Science Foundation. Serving more than 48,000 students, the three institutions of the USF System—USF in Tampa, USF St. Petersburg and USF Sarasota-Manatee—have an annual budget of \$1.5 billion and an annual economic impact of \$4.4 billion. USF is a member of the American Athletic Conference and a Charter Member Institution of the National Academy of Inventors.



Jesse Panuccio
Executive Director
Florida Department of Economic Opportunity

Jesse Panuccio is the Executive Director of the Florida Department of Economic Opportunity (DEO). He was appointed to this post by Governor Rick Scott in January 2013. As director of DEO, Panuccio coordinates and manages statewide workforce programs, community development opportunities, and economic development initiatives. Panuccio oversees the department's 1,600 employees and \$1 billion budget. During his tenure, the agency has implemented state-of-the-art fraud safeguards for unemployment insurance, streamlined the economic development incentive process, and launched the Competitive Florida Partnership to bring hands-on assistance and economic development to the state's rural counties. Prior to his appointment at DEO, Panuccio served as the General Counsel to Governor Scott, where he managed the legal affairs and staff of the Governor's office, helped direct and coordinate litigation and legal policy across state agencies, advised the Governor on judicial nominations, and served as the Governor's chief ethics officer. Before joining the Scott Administration, Panuccio practiced law with the Washington D.C.-based law firm of Cooper & Kirk PLLC. He received his J.D. from Harvard Law School and his bachelor's degree from Duke University.



Valencia Martin Wallace
Deputy Commissioner for Patent Quality
United States Patent and Trademark Office

Valencia Martin Wallace is Deputy Commissioner for Patent Quality. She was appointed to this newly-created position in January 2015. In her role as Deputy Commissioner for Patent Quality, she manages and leads the patent organization's quality initiatives. She is responsible for improving the high quality of the USPTO's patent examination processes and products by implementing and maintaining a comprehensive quality management system. As part of her twenty-two year career at the USPTO, she served as Assistant Deputy Commissioner for Patent Operations from 2011-2015. In the position, she oversaw operations in the software technology centers, served as executive co-lead on the implementation of the AIA First-Inventor-to-File statutory framework, and led the development and implementation of the Office of Patent Examination Support Services, which centralized the technical support staff in a manner that allowed for greater efficiency and effectiveness.



— 2015 —

FLORIDA INVENTORS HALL OF FAME

INDUCTEES



Henry Ford

Inventor and Businessman
Fort Myers
1863 - 1947

161 U.S. Patents

Henry Ford revolutionized the way Americans travel and shaped the course of the 20th century. Like his friend and mentor, Thomas Edison, Ford was an innovator, transforming the automobile from a luxury item to a practical means of transportation. Henry Ford's pioneering advancements in the automotive industry gave the average American the opportunity to travel freely. The explosive growth that followed led to the modern roadways and transportation systems that we know today.

A recipient of 161 patents, Ford not only revolutionized industrial manufacturing and production, but continued to improve upon his initial designs and explore new fields of automotive technology. Like Thomas Edison, Ford was a firm believer in finding natural solutions to industrial problems. Ford pioneered research in producing soybean plastics and finding new sources of natural rubber, and his quest for an American source of natural rubber led him to create two experimental rubber test sites in Florida, one of which—the Edison Botanic Research Corporation—was a collaborative effort with Thomas Edison and tire magnate Harvey Firestone. The groundbreaking work of the trio would lead to important botanical and chemical advancements, as well as aid passage of the Plant Patent Act of 1930 through Congress. Today, the Edison Botanic Research Corporation Laboratory, located in Fort Myers, has been designated a National Historic Chemical Landmark, the first such location in Florida.

Ford also conducted aeronautical research in Florida. Ford pilots flew several early Ford-manufactured aircraft in the state. Several Ford commercial aircraft were named after prominent Florida cities, including *Miss Fort Myers*. In addition, early experimental work on the highly secretive V-8 engine was also conducted in Florida, according to employees engaged in the project.

Florida remembers Henry Ford's contributions to science via the Edison Botanic Research Corporation Laboratory and *the Mangoes*, winter home of Henry Ford, both located in Fort Myers. Ford's legacy of innovation and keen interest in research and education continue to inspire new generations.



Photo Courtesy of Edison & Ford Winter Estates, Inc., Fort Myers, FL,
www.edisonfordwinterestates.org

2015 FLORIDA INVENTORS HALL OF FAME INDUCTEE



Robert Howard Grubbs, Ph.D.

2005 Nobel Prize in Chemistry
Victor and Elizabeth Atkins Professor of Chemistry
California Institute of Technology
Graduate, University of Florida
Gainesville

129+ U.S. Patents

Dr. Robert Howard Grubbs received his B.S. in chemistry in 1963 and M.S. in 1965, from the University of Florida in Gainesville. In 1998 he received his Ph.D. in chemistry from Columbia University. From 1968-1969 he was a National Institutes of Health (NIH) postdoctoral fellow in chemistry at Stanford University. He was at Michigan State University from 1969 to 1978, achieving the rank of associate professor. He is the Victor and Elizabeth Atkins Professor of Chemistry at the California Institute of Technology, where he has been a faculty member since 1978.

The Grubbs group discovers new catalysts and studies their fundamental chemistry and applications. Catalysts facilitate the transformation of organic molecules and are used widely in industry and academia for the preparation of important organic compounds and polymers. A family of catalysts for the interconversion of olefins, the olefin metathesis reaction was discovered in the Grubbs laboratory. In addition to their broad usage in academic research, these catalysts are now used commercially to prepare new pharmaceuticals, to create composites for structural applications, and to convert biorenewable carbon sources into fuels and commodity chemicals. Catalysts for other useful transformations are also being developed and studied in detail.

His more recent awards have included the Nobel Prize in Chemistry (2005), Benjamin Franklin Medal in Chemistry (2000), Pauling Award Medal (2003), Havinga Medal (2006) (Leiden University), Golden Plate Award (2006) (Academy of Achievement), Gold Medal of the American Institute of Chemists, Chemical Heritage Foundation (2010), and Giulio Natta Award for Chemistry (2014), as well as eight American Chemical Society honors, including the Award in Polymer Chemistry (1995), Arthur C. Cope Award (2002), Award for Creative Invention (2009), and Roger Adams Award in Organic Chemistry (2011). He has been elected a member of the National Academy of Sciences (1989), a fellow of the American Academy of Arts and Sciences (1994), an honorary fellow of the Royal Society of Chemistry (2005), a fellow of the American Chemical Society (2009), a fellow of the National Academy of Inventors (2013), and a member of the National Academy of Engineering (2015). He has been awarded many honorary degrees, most recently a DSc from the University of Warwick, Coventry, in 2010; an Honoris Causa Doctorate, Universidad de Huelva, Spain, in 2012; and an RWTH Aachen University Honorary Doctorate (Dr. rer.nat.h.c.), in 2013; and he was Commencement Speaker at King Abdullah University of Science and Technology, Saudi Arabia, in 2013. He has over 580 publications and over 129 U.S. patents based on his research.

Photo Courtesy of Lance Hayashida/Caltech.

Robert Holton, Ph.D.

Matthew Suffness Professor of Chemistry
Florida State University
Tallahassee

125+ U.S. Patents

Dr. Robert Holton, whose research focuses on the synthesis of complex organic molecules, is a leader in the field of synthetic chemistry. Holton is most often recognized for being the first to synthesize Taxol, a powerful and widely used cancer-fighting agent. Over his career, his work on taxane natural products has led to significant advancements in cancer research and treatment. Besides Taxol, Holton was able to synthesize a range of natural products. Most notable are Prostaglandin F2a, a naturally occurring prostaglandin used in medicine to induce labor; Narwedine, an important chemical reaction compound; Aphidicolin, an antibiotic with antiviral and antimitotical properties; Taxusin; and Hemibrevitoxin.

Holton began his academic career as an undergraduate at the University of North Carolina and later received his Ph.D. in chemistry from Florida State University. After holding positions at Stanford University, Purdue University, and Virginia Tech, he eventually returned to Florida State in 1985 to teach and conduct research. In 1997, Holton co-founded Taxolog, Inc., along with his colleague Lewis Metts. For more than a decade, Taxolog continued to develop and commercialize unique drugs based on taxanes for the treatment of cancer and other diseases. Today, Holton is the Matthew Suffness Professor of Chemistry at FSU, where his research group continues to study the synthesis of taxane natural products and their application to cancer treatment.

Holton holds over 125 issued U.S. patents. His accomplishments are a testament to his dedication to science and medicine. His Taxol was the top selling anti-cancer drug in 1995 and generated over \$1.6 billion in revenues by the end of the decade. In addition, Taxol generated the largest patent payout in history for a single university (FSU).

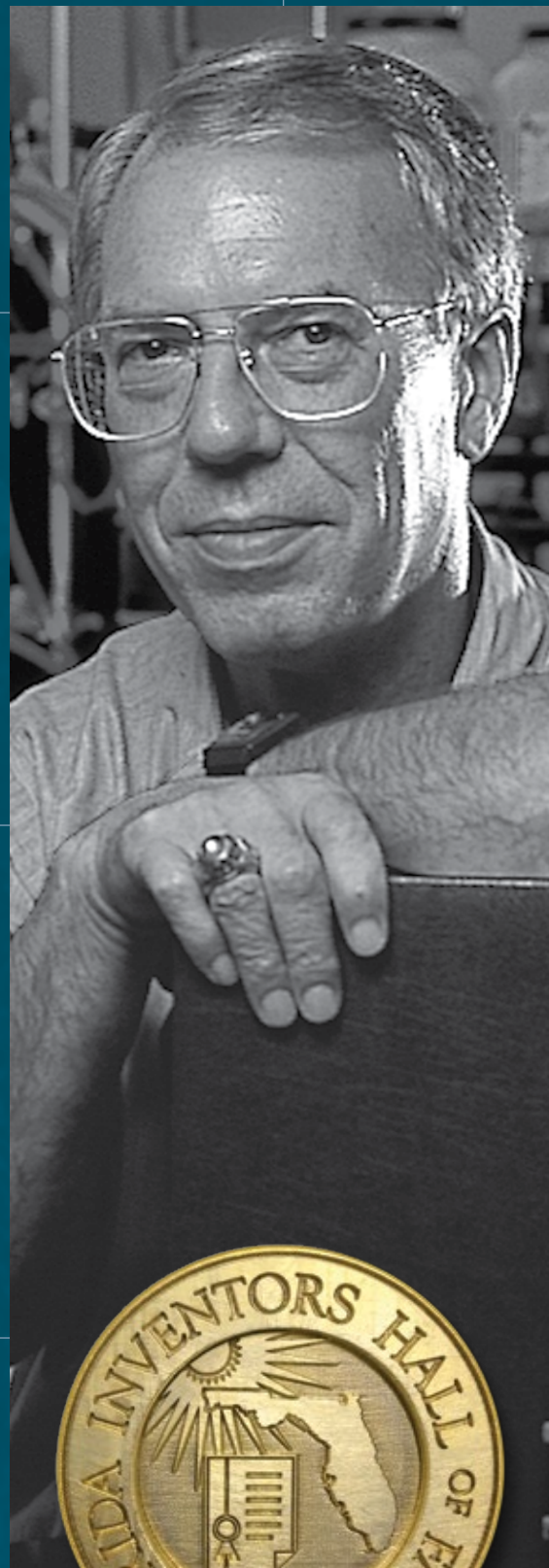

2015 FLORIDA INVENTORS HALL OF FAME INDUCTEE



Jerry Pratt, Ph.D.

Research Scientist
Florida Institute for Human & Machine Cognition
Pensacola

6 U.S. Patents

Dr. Jerry Pratt leads a research group at the Florida Institute for Human & Machine Cognition (IHMC) that concentrates on understanding and modeling human gait and applying that knowledge to the fields of robotics, human assistive devices, and man-machine interfaces. Current projects include humanoid avatar robots for co-exploration of hazardous environments, fast and efficient biologically-inspired running robots, and exoskeletons for restoration of gait in paralyzed individuals.

Pratt is a recognized expert in bipedal walking, with his algorithms used in various robots around the world. In particular, he holds several patents on algorithms for humanoid robots to recover their balance after being pushed, even when available footholds are sparse. In 2015, Pratt and his IHMC team placed second out of 23 world-wide teams in the DARPA Robotics Challenge and placed first among humanoid robots that primarily walk bipedally.

Pratt's teams' approach of maximizing speed, agility, and biological similarity through the understanding of biological counterparts is helping to remove the stereotype of robots as clunky, jerky-moving machines. Recent work on fast running robots has resulted in ostrich-inspired running models and robot prototypes that are currently believed to be the fastest running robots in the world.

Pratt was involved in pioneering work as an undergraduate at the Massachusetts Institute of Technology (MIT), where he designed early prototypes of computer network interface cards and motion tracking systems. As a graduate student, he developed one of the first bipedal robots that could compliantly walk over rough terrain. After graduation, Pratt and colleagues founded a small company, where they invented the RoboKnee, one of the first exoskeletons that increased human strength and endurance, and the IntelligentPatientLift, which allows for caregivers to directly lift patients, rather than requiring operation through a control pendant.

Pratt has always been a tinkerer. While a teen, he wrote a drawing and painting program before they were commercially available and built several robots. As a high school senior, he invented the "Knock-Out Keyless Door Lock," a lock which requires one to knock a user-programmable code on a door in order to unlock it. This invention won first place in the 1990 NSTA Design a Duracell Device Scholarship Competition.

Pratt lives in Pensacola with wife Megan and children Ben and Annie. The Pratts co-founded the Pensacola MESS (Math Engineering Science and Stuff) Hall, a hands-on science museum, featuring its signature "Mess Kits," innovative hands-on science experiments for all ages.

Paul R. Sanberg, Ph.D., D.Sc.

Founder and President, National Academy of Inventors
Senior Vice President for Research, Innovation &
Economic Development; Executive Director, Center for
Excellence for Aging and Brain Repair; Distinguished
University Professor
University of South Florida
Tampa

41 U.S. Patents

Neuroscientist Dr. Paul R. Sanberg's work has been instrumental in understanding and developing new pharmaceutical and cellular therapeutics for stroke, Alzheimer's, ALS, Huntington's, Parkinson's disease and Tourette syndrome. His research has involved discovering innovative ways to repair the damaged brain and has helped lead the team that demonstrated the use of umbilical cord blood-derived cells for neurological disease. He holds 41 U.S. and 70 foreign patents.

Sanberg trained at York University, University of British Columbia, Australian National University and Johns Hopkins University School of Medicine, and held faculty appointments at the University of Cincinnati and Brown University, among others, prior to joining the University of South Florida as a professor in 1992. He was a long time member of the Board of Scientific Counselors for the National Institute on Drug Abuse at the National Institutes of Health and has served on numerous scientific advisory boards for health-related foundations and companies. He has industry experience as a founder or director of a number of companies involved in cell therapy for degenerative disorders. He is the author of more than 600 articles and 14 books, with over 24,000 citations to his published work, has served on editorial boards for more than 30 scientific journals, and is editor-in-chief of *Technology and Innovation: Journal of the National Academy of Inventors*.

Sanberg is founder, president, and a Charter Fellow of the National Academy of Inventors. He is the 2015 Medalist of the Florida Academy of Sciences; a Fulbright Specialist; fellow of the American Association for the Advancement of Science (AAAS), American Institute for Medical and Biological Engineering, and Royal Societies of Chemistry, Public Health and Medicine; and AAAS-Lemelson Invention Ambassador. He serves on the nomination evaluation committee of the U.S. National Medal of Technology and Innovation with the U.S. Department of Commerce, Smithsonian Innovation Festival selection committee, and advisory board of the APLU Commission on Innovation, Competitiveness, and Economic Prosperity.



2015 FLORIDA INVENTORS HALL OF FAME INDUCTEE



Nan-Yao Su, Ph.D.

Distinguished Professor of Entomology
Fort Lauderdale Research and Education Center
University of Florida
Gainesville and Fort Lauderdale

11 U.S. Patents

Dr. Nan-Yao Su is one of the world's leading authorities on subterranean termites and their management. Along with colleagues at Dow AgroSciences, he developed a revolutionary approach for protecting homes and other buildings from these wood-consuming insects, the Sentricon® termite colony elimination system.

For much of the 20th century, the standard treatment for subterranean termites involved application of liquid insecticide to soil around the exterior of a building. This method was not environmentally sustainable and not always successful at stopping infestations because it only killed termites in the treated area. Subterranean termites can travel hundreds of feet from their nests to forage.

Beginning in the late 1980s, Su and Dow scientists pioneered a safe, effective new approach to termite management, using a slow-acting compound called hexaflumuron. It kills termites by interfering with their molting process. The team incorporated hexaflumuron into a bait that could be placed underground in feeding stations. Foraging termites would feed on the bait and carry portions back to the nest to share with other members of the colony. This was a key advantage because it meant the bait could reach the majority of termite workers and potentially destroy the colony. Hexaflumuron is harmless to people and pets and poses no threat to other insect species when properly used.

In 1995, the Sentricon® system became commercially available. Since then, it has been used in 18 countries, protected more than 3 million homes, and saved more than 9,000 metric tons of insecticide that would have been applied otherwise. Su has used the system to protect historic landmarks including the Statue of Liberty, and has helped fight large-scale termite infestations in New Orleans and in other countries including Chile, China, New Zealand, and Vietnam.

To honor his accomplishments with Sentricon®, Su has received numerous awards, including the Presidential Green Chemistry Challenge Award from the U.S. Environmental Protection Agency. He has authored and co-authored more than 250 peer-reviewed articles and book chapters on termite biology and management.

He received a B.S. in 1975 and an M.S. in 1977 from Kyoto Institute of Technology and a doctorate in entomology from the University of Hawaii in 1982. Su has been with the University of Florida since 1984 and works at the Fort Lauderdale Research and Education Center.

Su has received 11 U.S. patents and continues to develop innovations to make the Sentricon® system more practical, effective, and affordable.

Janet Yamamoto, Ph.D.

Professor
College of Veterinary Medicine
University of Florida
Gainesville

20 U.S. Patents

Dr. Janet K. Yamamoto is a professor of retroviral immunology in UF Veterinary Medicine's department of infectious diseases and pathology. She received her Ph.D. in microbiology, with a focus in immunology, from the University of Texas Medical Branch at Galveston. In 1984, she established the HIV/AIDS BSL3 laboratory under the joint directive of the Schools of Medicine and Veterinary Medicine at the University of California Davis, which was later awarded Center for AIDS Research funds for the northern California region from NIH.

Yamamoto, together with Nobel laureate Dr. Françoise Barré-Sinoussi, was the first to demonstrate and publish that interferon-gamma will not protect against HIV-1, and she has served as the consultant for the second FDA-approved HIV-1 Western blot for HIV-1 confirmatory test. Yamamoto co-discovered, characterized, and co-patented feline interferon-omega which was commercially released in Europe and recently in the U.S. as a supplemental therapy against viral diseases of cats. As a part of the world effort to discover a small animal model for HIV/AIDS, in 1986 she co-discovered the feline immunodeficiency virus, FIV, the feline counterpart of HIV. She also invented the first commercial FIV vaccine, sold by Pfizer-Zoetis and Boehringer.

Yamamoto's laboratory has studied the immune mechanisms of protection conferred by her FIV vaccine and determined that the major portion of this vaccine protection against global FIV isolates is mediated by anti-FIV T-cell immunity rather than by antibody immunity. Her team has also discovered that AIDS viruses such as FIV and HIV-1 carry, as part of their structural proteins and enzymes, protein pieces called epitopes that enhance viral infection, whereas other epitopes may inhibit infection. Her laboratory is currently selecting anti-AIDS viral T-cell epitopes that are conserved among FIV, SIV and HIV-1 to minimize mutational affect and to broaden protective efficacy. Since these epitopes are conserved between FIV and HIV-1, the FIV sequences of such epitopes have been formulated as synthetic peptides and tested against FIV in laboratory cats. A pilot study showed a promising result with only a few T-cell epitopes, and currently a major trial using a large number of T-cell epitopes is ongoing. If successful, the HIV counterpart epitopes will be used to develop an effective T-cell-based HIV vaccine for humans. When used in combination with antiretroviral drugs, these vaccines have the potential to cure HIV and FIV infections in HIV-positive humans and infected cats, respectively.

Yamamoto holds 20 U.S. and 14 foreign patents and donates all of her personal patent royalty and licensing income to her research.



2015 SELECTION COMMITTEE

Randy E. Berridge *(see page 8)*



Sharon A. Heise, Associate Director
Institute for Human & Machine Cognition

Dr. Sharon Heise is associate director at the Florida Institute for Human & Machine Cognition in Pensacola. As a member of IHMC's senior leadership team, Heise oversees all aspects of IHMC research initiatives. She previously served 20 years in the U.S. Air Force, where she was most recently director of mathematics and information sciences at the Air Force Office of Scientific Research. She holds a Ph.D. in control engineering from Cambridge University, U.K. She is a graduate of the Program for Senior Executives in National and International Security at the Kennedy School of Government, Harvard University.



David R. Makufka, Manager
Technology Transfer Office, John F. Kennedy Space Center

David Makufka has more than 30 years of experience in aerospace engineering, design and development, technology transfer, and the creation of public-private partnerships at NASA's John F. Kennedy Space Center (KSC), including the management of KSC's Technology Transfer Office since 2006. In this role, he manages the implementation of the Center's technology transfer activities, including oversight of intellectual property management and technology licensing; establishing cost-shared technology development partnerships with non-NASA participants; and providing strategic guidance for patent protection and technology investments. He has directly led or assisted in the execution of dozens of patent and copyright license agreements and has created numerous joint development partnerships with industry, academia, and other government organizations for the development of technologies to meet NASA's mission needs and provide benefit to the nation. Makufka is a graduate of the Pennsylvania State University with a B.S. in Mechanical Engineering.



David P. Norton, Vice President for Research
University of Florida

Dr. David P. Norton is vice president for research at the University of Florida (UF). Previously, he served as associate dean for research in the College of Engineering and professor in the Department of Materials Science and Engineering. He has 23 years of experience in science and technology research, having served 11 years as a research scientist at Oak Ridge National Laboratory (ORNL) prior to joining UF as a faculty member in 2000. Throughout his career at ORNL and UF, he has published over 350 refereed journal articles with more than 11,000 citations. He is an inventor on 10 patents and has presented more than 70 invited presentations at national and international conferences. Norton is a fellow of the American Physical Society, American Vacuum Society, and American Association for the Advancement of Science (AAAS) and Charter Fellow of the National Academy of Inventors. He holds B.S. and Ph.D. degrees in Electrical and Computer Engineering from Louisiana State University.



Gary K. Ostrander, Vice President for Research
Florida State University

Dr. Gary K. Ostrander is vice president for research, president of the Research Foundation, and professor of medicine at Florida State University. He completed his Ph.D. at the University of Washington and postdoctoral training at the UW Medical School. He previously served as a faculty member and administrator at Oklahoma State University, Johns Hopkins University, and the University of Hawaii. His research initially focused on exploiting novel aspects of the biology of fishes to address fundamental questions of cancer biology. Recently, his efforts have been aimed at understanding the worldwide deterioration of coral reef ecosystems. He has authored/co-authored more than 80 peer-reviewed publications and edited or authored five books.



M.J. Soileau, Vice President for Research & Commercialization
University of Central Florida

Dr. M.J. Soileau oversees UCF's sponsored research activities (\$133.4 million in FY15), management of interdisciplinary centers and institutes, including the Institute for Simulation and Training, and the university's extensive commercialization programs. In 2013, UCF's Business Incubation Program was named best incubator network of the year by the National Business Incubation Association, and UCF patents are currently ranked among the top 15 among public universities in the U.S. Soileau holds a Ph.D. in electrical engineering/quantum electronics from the University of Southern California. He was the founding director of UCF's CREOL, the College of Optics and Photonics. He is a Charter Fellow of the National Academy of Inventors.



Jack Sullivan, Jr., CEO
Florida Research Consortium

Since 2003, Jack Sullivan has been the president and CEO of the Florida Research Consortium (FRC), a strategic partnership between Florida's research assets and the business community, focused on enhancing progressive research programs in Florida to promote quality economic growth. Sullivan joined the FRC after a successful private sector career, and he continues to manage a portfolio of commercial and agricultural real estate. Sullivan's current volunteer service includes the not-for-profit boards of BioFlorida, the Florida Chamber Foundation, and Florida Lambda Rail. He earned a B.A. from Davidson College and MBA from Vanderbilt University.



Wendy Walker, President
Leadership Florida

Wendy Walker is president of Leadership Florida, a position she has held for 26 of the organization's 34 years. During that time, Leadership Florida has grown from producing an annual class program to providing programs for the state's top college students, locally elected officials from cities, counties and school boards, new executives in Florida, graduates of community leadership programs, educators and members of the Florida Legislature. Leadership Florida is also well known for producing televised debates between candidates running for Governor, the U.S. Senate and President of the United States, for its anti-discrimination campaign, the *Faces of Florida*, and for creating and producing the Sunshine State Survey. Walker has served as president of the Economic Club of Florida and currently serves on the boards of the Florida College System Foundation, Florida State University's Opening Nights Performing Arts, and the Tallahassee Village Square.

2015 ADVISORY BOARD

Randy E. Berridge (see page 8)



Senator Jeffrey P. Brandes
Florida Senate, 22nd District

Florida State Senator Jeff Brandes represents Florida Senate District 22, which includes parts of Hillsborough and Pinellas County. He was originally elected to the Florida House of Representatives in 2010 and was subsequently elected to the Florida Senate in 2012. He serves as Chairman of the Senate Committee on Transportation. He also serves on a number of other committees including the Senate Committees on Community Affairs, Education, and Judiciary. Previously, he served on the Meet the Need™ board of directors from 2010 to 2012. Prior to that, he served in the U.S. Army Reserves as a Transportation officer from 1996 to 2007. During his time in the Army Reserves, he served a tour of duty in Iraq from 2003 to 2004. Currently, he is a member of Bay Cities Bank board of directors and is a member of Leadership St. Petersburg.



Curtis R. Carlson
Author, Inventor and Entrepreneur

Dr. Curtis R. Carlson is founder and CEO of The Practice of Innovation, an organization dedicated to improving innovative performance. From 1988 to 2014, Carlson served as president and CEO of SRI International, a world authority on creating value for customers through innovation. In 1973, he joined RCA Laboratories, which became part of SRI in 1987 as Sarnoff Corporation. There, Carlson started and helped lead development of HDTV technology that became the U.S. standard, for which he and his team won an Emmy® Award. His book with William Wilmot, *Innovation: The Five Disciplines for Creating What Customers Want*, describes how SRI's unique process for innovation can be applied to all types of government and commercial enterprises. He is a Charter Fellow of the National Academy of Inventors.



Kathy Castor
U.S. Representative
Florida's 14th Congressional District

Kathy Castor is the U.S. Representative for Florida's 14th congressional district, serving in Congress since 2007. Castor is the first woman to represent Hillsborough and Pinellas counties in the U.S. Congress. She serves on the House Energy & Commerce Committee and the Budget Committee. Before her election, Castor served as a Hillsborough County Commissioner and chair of the Hillsborough County Environmental Protection Commission. She is a graduate of Emory University and Florida State University College of Law, former president of the Florida Association of Women Lawyers, and a partner in a statewide law firm.



Anthony James Catanese, President
Florida Institute of Technology

Dr. Anthony James Catanese is president of the Florida Institute of Technology, a major research institution with more than 16,000 students. Florida Tech emphasizes academic and research programs in engineering, the sciences, liberal arts, business, psychology and aeronautics. It has a major distance learning program using advanced technology. Such groups as the Carnegie Foundation and *U.S. News and World Report* rate it amongst America's top universities. A prolific writer, Catanese has published 13 books, 18 chapters in books, and more than 100 articles and monographs. He is a member of the College of Fellows of the American Institute of Certified Planners, was appointed by President Jimmy Carter to serve on the National Urban Policy Task Force, and served as chair of the Milwaukee City Planning Board and the Gainesville City Planning Commission.



Molly Demeulenaere, President and CEO
Museum of Science and Industry (MOSI)

As president and CEO of MOSI, Demeulenaere oversees all fundraising activities, including strategic partnerships, annual giving, capital and endowment campaigns, fundraising events, and donor development, along with the museum's overall operations, including financials, facility, marketing, programming, and education. Demeulenaere is known for her ability to build relationships with all different types of constituencies, while her passion for science and informal education supports MOSI's core ideology of changing people's lives by making science real. She currently serves as a board member of the Florida Association of Museums (FAM) and on the Association of Science and Technology Centers' (ASTC) development committee. Prior to joining MOSI, Demeulenaere served GWIZ – The Science Museum, the Science and Environment Council of Sarasota County, and the Sarasota County Arts Council.



Jonathan M. Ellen, President and Physician-in-Chief
All Children's Hospital

Dr. Jonathan M. Ellen is president and physician-in-chief of All Children's Hospital, a member of Johns Hopkins Medicine and vice dean for All Children's Hospital and professor of pediatrics in Johns Hopkins University School of Medicine. He is leading the transformation of All Children's from a regional pediatric referral center to an academic children's hospital and national leader in research, teaching, and patient care. Ellen has worked with leaders of the University of South Florida Morsani College of Medicine to strengthen the ACH-USF affiliation and their combined efforts in pediatric education and research. He is teaming up with a variety of community hospitals and providers in the Tampa Bay region and beyond to expand pediatric networks that ensure optimal care for children with complex and chronic medical conditions. He has received more than \$25 million in research awards from the Centers for Disease Control (CDC), NIH, and other agencies. Ellen has authored more than 200 peer-reviewed scientific articles and 30 reviews, editorials, and book chapters.



Kenneth Ford, Founder and Director
Florida Institute for Human & Machine Cognition

Dr. Kenneth Ford is founder and director of the Florida Institute for Human & Machine Cognition (IHMC), an independent not-for-profit research institute. Ford's research interests include: artificial intelligence, cognitive science, human-centered computing, and entrepreneurship in government and academia. He received a Ph.D. in computer science from Tulane University. Ford has served on the National Science Board, the Air Force Science Advisory Board, and the Defense Science Board and served as chairman of the NASA Advisory Council. Ford is a fellow of the Association for the Advancement of Artificial Intelligence (AAAI), a Charter Fellow of the National Academy of Inventors, and has received many awards and honors including the *Doctor Honoris Causas* from the University of Bordeaux in 2005, the 2008 Robert S. Englemore Memorial Award for his work in artificial intelligence, the 2012 Tulane University *Outstanding Alumnus* in the School of Science and Engineering. In 2015 he received the AAAI Distinguished Service Award.

Judy Genshaft, President (see page 8)



William Scott Green, Senior Vice Provost and Dean of Undergraduate Education
University of Miami

As senior vice provost and dean of undergraduate education, Dr. William Scott Green is responsible for developing and strengthening university-wide components of undergraduate learning. He has worked to enhance, devise, and appropriately support programs in such areas as study abroad, academic advocacy for underrepresented students, career services, learning assistance, civic engagement, undergraduate research, and the honors program. Green currently holds an appointment as professor of religious studies and senior fellow in the University of Miami's Sue and Leonard Miller Center for Contemporary Judaic Studies. He is former editor of the *Journal of the American Academy of Religion*, the leading scholarly periodical in religion. Among other professional activities, he served on the board of the Association of American Colleges and Universities and the Reinvention Center, a consortium of major research universities committed to improving undergraduate education.



John Hitt, President
University of Central Florida

Dr. John C. Hitt became the fourth president of the University of Central Florida on March 1, 1992. A physiological psychologist, he had prepared for this presidency throughout his career as a scholar, dean, provost, vice president for academic affairs, and interim university president. Under his leadership, enrollment at UCF has nearly tripled, the number of doctoral degrees awarded each year has increased eightfold, research funding has increased from \$28 million to \$133 million a year, and UCF has founded its own College of Medicine. In recent years, Hitt has received a number of prestigious awards and honors, such as induction in the National Center for Simulation Modeling and Simulation Hall of Fame and placement among the Orlando Sentinel's 25 Most Powerful People in Central Florida and Orlando Magazine's 50 Most Powerful People. He also received the Orlando Business Journal's first-ever Legacy Award and the Orlando Sentinel's 2005 Central Floridian of the Year Award.



Richard A. Houghten, Founder, President and CEO
Torrey Pines Institute of Molecular Studies

Dr. Richard A. Houghten is founder, CEO and president of Torrey Pines Institute for Molecular Studies, a not-for-profit, bi-coastal medical research organization. Now in its 27th year, it has become internationally recognized for its scientific contributions. He has held positions at the University of California, San Francisco, Mount Sinai School of Medicine, and The Scripps Research Institute. His many awards include the 2004 Ralph Hirschmann Award in Peptide Chemistry by the American Chemical Society, the 2005 Bruce Merrifield Award by the American Peptide Society, and UCSD Connect's Athena Pinnacle Award for Empowering Women in the Workplace. He has over 500 publications, 75 U.S. and 47 foreign patents. Houghten is an American Association of Pharmaceutical Sciences Fellow, American Association for the Advancement of Science (AAAS) Fellow, and a Charter Fellow of the National Academy of Inventors.



Richard Jove, Director
Cell Therapies Institute, Nova Southeastern University

Dr. Richard Jove received his doctoral training at Columbia University and post-doctoral training at Rockefeller University. He began his career at the University of Michigan, Ann Arbor. Subsequently, Jove helped establish the Moffitt Cancer Center as professor and director of the Molecular Oncology Program. He then was deputy director of the National Cancer Institute Comprehensive Cancer Center and director of the Beckman Research Institute at City of Hope National Medical Center in Los Angeles. Jove served as director of the Vaccine and Gene Therapy Institute of Florida from 2013-2015. In October of 2015, Jove became Distinguished Research Professor and Research Institute Director at Nova Southeastern University.



Paul Lemmo
*Vice President, Fire Control/Special Operations Forces
Contractor Logistics Support Services (SOF CLSS)
Lockheed Martin Missiles and Fire Control*

Paul Lemmo is vice president of Fire Control/SOF CLSS for Lockheed Martin Missiles and Fire Control. Previously, he was senior vice president of corporate strategy and business development and a member of Lockheed Martin's executive leadership team. He has more than 27 years of experience in business development, engineering and program management. Prior roles include vice president of business development and strategy at two Lockheed Martin business areas: Information Systems and Global Solutions (IS&GS) and Mission Systems and Sensors (MS2). He is a graduate of the General Electric Edison Engineering Program and received bachelor and master's degrees in electrical engineering from Drexel University and an MBA from The Wharton School of the University of Pennsylvania. He currently serves as an executive board member for the D.C. chapter of Operation Homefront, a national charitable organization providing assistance to wounded warriors and their families, and to the families of deployed military service members.



Alan List, President and CEO
Moffitt Cancer Center

Dr. Alan List is president and chief executive officer of Moffitt Cancer Center in Tampa. He is internationally recognized for his many contributions in the development of novel, more effective treatment strategies for myelodysplastic syndrome (MDS) and acute myeloid leukemia (AML). List lectures nationally and internationally and is the author of more than 300 peer-reviewed articles. He is active in numerous professional organizations and serves on the board of the American Society of Hematology. List is a Charter Fellow of the National Academy of Inventors and holds six patents.



Phoebe Cade Miles, President
Cade Museum

Phoebe Cade Miles founded the Cade Museum in 2004. She is also co-founder and vice-president of the Gloria Dei Foundation, a family-operated charity that awards grants to organizations that promote the common good in accordance with Christian principles. Both Gloria Dei and the Cade Museum Foundation were endowed with gifts by Miles' parents, Dr. Robert Cade and Mary Cade. Dr. Cade, a University of Florida researcher and physician who passed away in November 2007, was best known as the leader of the team that invented Gatorade in 1965 and was inducted into the Florida Inventors Hall of Fame in 2014. A native of Gainesville, Florida, Miles has lived much of her adult life overseas, accompanying her husband to official postings with the U.S. Army in Nuremberg, Germany, and with the U.S. State Department in Bridgetown, Barbados; Berlin, Germany; and Buenos Aires, Argentina.



Arthur Molella, Director Emeritus
Smithsonian's Lemelson Center for the Study of Invention & Innovation

Dr. Arthur Molella is the Jerome and Dorothy Lemelson Director Emeritus of the Smithsonian Institution's Lemelson Center for the Study of Invention & Innovation at the National Museum of American History. He is the Center's founding director. He is also Senior Lecturer of History of Science and Technology at the Johns Hopkins University. He was head curator of the Smithsonian's Science in American Life exhibition and co-curator of the international exhibition, Nobel Voices, a celebration of the centenary of the Nobel Prize. He has published and lectured widely on the relations between science, technology, and culture. His publications include *Inventing for the Environment* (ed. with Joyce Bedi, MIT, 2003) and *Invented Edens: Techno-Cities of the 20th Century* (with Robert Kargon, MIT, 2008). Molella served on the selection committee for the National Inventors Hall of Fame, including special Blue Ribbon panels for historical inductees. He currently sits on the boards of the National Academy of Inventors, the National Inventors Hall of Fame and the MIT Museum.



Jeremy Montague, President
Florida Academy of Sciences

Dr. Jeremy Montague, professor of biology at Barry University, is the current president of the Florida Academy of Sciences (2015-2017), having served previously as the FAS Program Chair (2003-2012) and FAS Secretary (2010-2015). He has been with Barry University since 1983. He earned his B.S. cum laude at SUNY College at Geneseo, M.S. at Kent State University, and his Ph.D. at Syracuse University. At the undergraduate level he has taught introductory biology, botany, zoology, ecology, marine biology, and evolution; at the graduate level he has taught biostatistics, experimental design, and epidemiology. He has authored or co-authored 33 peer-reviewed articles in professional journals, focusing mainly on statistical work in terrestrial ecology, marine biology, cell biology, and educational program assessment. He is the current secretary for the Barry University Chapter of the Sigma Xi National Honor Society (1998-present).



Ed H. Moore, President
Independent Colleges and Universities of Florida

Dr. Ed H. Moore is president of the Independent Colleges and Universities of Florida (ICUF), a Tallahassee-based association of 30 private, not-for-profit colleges and universities. He serves as executive director of the Higher Education Facilities Finance Authority in Florida. He was the 2013 national chairman of the National Association of Colleges and Universities State Executives. Moore co-wrote and edited a manual for the U.S. Department of State, *The Power of Ideas*. He is a Florida advisor for the U.S. Global Leadership Conference and was awarded a Fulbright Specialist Grant to seek expanded higher education exchanges between the Republic of China and Florida.



JoAnn Newman, President and CEO
Orlando Science Center

JoAnn Newman came to the Orlando Science Center in February 2003 as director of exhibits and became vice president for exhibits and operations in 2006. She was named president and CEO in 2009 and has successfully directed the development of many new exhibitions and programs. During her tenure, she has led the teams responsible for implementing the original exhibits, *Touch the Sky* and *Discover the Daytona 500*, and the extremely popular *Otronicon* events. Newman was also responsible for overseeing daily operations, human resources, and the overall guest experience. She holds M.S. and B.S. degrees in Industrial Engineering from Purdue University and Pennsylvania State University, respectively. She has more than 20 years of engineering, operations, and management experience with high technology companies, including AT&T Microelectronics, Cirent Semiconductor, and Agere Systems.



James C. Paulson, Professor and Chair

Department of Cell and Molecular Biology, The Scripps Research Institute

Dr. James Paulson has been a full-time faculty member at The Scripps Research Institute (TSRI) since 1999. He previously served as chair of the Department of Cell and Molecular Biology from 2013-2014 and as acting president and CEO of TSRI from 2014-2015. Paulson earned his Ph.D. at the University of Illinois at Champaign-Urbana and conducted postdoctoral work at Duke University Medical Center in Durham, North Carolina from 1974-1978. From 1978-1990, Paulson served on the faculty of UCLA School of Medicine. He then spent almost 10 years at Cytel Corporation in roles including vice president for research development, chief scientific officer, and general manager. Paulson's current research focuses on the role of carbohydrate binding proteins in the regulation of immune function. He has published more than 250 publications and is the recipient of numerous professional awards.



Janet E. Petro, Deputy Director

John F. Kennedy Space Center

Janet E. Petro is the deputy director of NASA's John F. Kennedy Space Center in Florida. Appointed to the deputy director position in April 2007, she shares responsibility with the center director in managing the Kennedy team of approximately 8,600 civil service and contractor employees, determining and implementing center policy, and managing and executing Kennedy missions and agency program responsibilities. She served a 12-month appointment at NASA Headquarters in Washington, D.C. as the deputy associate administrator and acting director for the Office of Evaluation. Petro began her professional career as a commissioned officer in the U.S. Army after graduating in 1981 from the U.S. Military Academy at West Point with a Bachelor of Science in engineering. She served in the U.S. Army's aviation branch with various assignments overseas in Germany. She also holds an MBA from Boston University's Metropolitan College.



John B. Ramil, President and CEO

TECO Energy

John B. Ramil was named president and CEO of TECO Energy in August 2010. Before that, Ramil had served as president and chief operating officer since July 2004. Ramil was named to the company's board of directors in January 2008. He was formerly president of Tampa Electric Company and executive vice president of its holding company, TECO Energy. Ramil also served as vice president-finance and chief financial officer for TECO Energy and, earlier, as vice president-Energy Services & Planning for Tampa Electric. Ramil was elected in June 2010 to the board of the Edison Electric Institute. He also sits on the corporate board of Blue Cross and Blue Shield of Florida, Inc. In 2001, he was appointed by Florida Governor Jeb Bush to the charter Board of Trustees of the University of South Florida and was elected chair of the board in June 2010. He also serves on the boards of the Florida Chamber of Commerce, the Tampa Bay Performing Arts Center and is a past chair of the Greater Tampa Chamber of Commerce, the American Heart Association-Tampa Bay Heart Walk, InRoads Tampa Bay, the Southeastern Electric Exchange, and the Florida Electric Power Coordinating Group.



Grover C. Robinson IV, Commissioner, BCC District 4

President, Florida Association of Counties

Grover C. Robinson IV is a seventh generation Pensacolian who grew up in Escambia County's District 4. First elected to his home district in 2006, Robinson became a Florida Certified Commissioner in June 2008 and served as the Escambia County Board of County Commissioners' chairman in 2009. Robinson received a Bachelor of Science degree in Economics (summa cum laude) from Birmingham-Southern College.



Mark B. Rosenberg, President

Florida International University

Dr. Mark B. Rosenberg is the fifth president of Florida International University. He brings over 35 years of experience in higher education leadership to this post. The author of seven books and numerous scholarly articles on Latin America, Rosenberg was one of the principal architects of FIU's growth and expansion during the past decade and played a lead role in development of FIU's new Herbert Wertheim College of Medicine. Most recently, he served as chancellor of the State University System of Florida and was instrumental in developing a new financial strategy to support the continuing development and expansion of the State University System. Rosenberg holds a Ph.D. from the University of Pittsburgh and a B.A. from Miami University of Ohio, where he was Phi Beta Kappa. He is a Fulbright Research Scholar and a member of the Council on Foreign Relations in New York.



Dennis A. Ross, U.S. Representative

Florida's 15th Congressional District

Representative Dennis Ross is a staunch advocate on behalf of his constituents in central Florida. He is currently serving his third term in the U.S. House of Representatives. He studied Organizational Management at Auburn University's School of Business and earned his Juris Doctorate from Cumberland School of Law at Samford University in Alabama. Ross has worked in a private law firm, served as in-house counsel for Walt Disney World, and later started his own practice. He was elected to the state legislature in 2000, where he represented central Florida for four terms.

Paul R. Sanberg, Chair *(see page 15)*



Mark Sharpe, Executive Director
Tampa Innovation Alliance

A Tampa native, Mark Sharpe became executive director of the Tampa Innovation Alliance in 2014. He previously was elected to the Hillsborough County Commission in Countywide District 7 seat in 2004. He was re-elected in 2006 and again in 2010 to serve his final four-year term. Sharpe was the Board's vice chairman from 2007-2011. Prior to his election, Sharpe served eight years as an active-duty officer in the U.S. Navy. He retired after two decades of service, which included 12 years in the U.S. Naval Reserves. Sharpe is chairman of the Hillsborough Metropolitan Planning Organization and an active member of the Hillsborough Area Regional Transit Authority (HART). He served on the boards of directors for the Tampa Hillsborough Economic Development Corporation and Tampa Bay Partnership and also represented the County Commission on the boards of the Museum of Science and Industry and Tourist Development Council. After being termed out in 2014, Sharpe accepted his current position with the Tampa Innovation Alliance, where he has continued his efforts to bring jobs and improve Hillsborough County.



Gillian Thomas, President and CEO
Miami Science Museum

Gillian Thomas has been with the Miami Science Museum since early 2003, first as a consultant and, beginning in August 2003, as president and CEO. During her tenure with the Museum, the Miami-Dade County Building Better Communities General Obligation Bonds were approved by voters, awarding \$175 million towards the construction of the new Patricia and Phillip Frost Museum of Science in downtown's Museum Park. Under Thomas' leadership, ground was broken on the new project in 2012 and more than \$99 million has been raised in pledges to support it. The new Museum is slated to open in 2016. Thomas was awarded an OBE (Order of the British Empire) by Queen Elizabeth II in January 2000 for her work at the @Bristol Science Center, where she served as CEO, and its impact on the revitalization of the downtown area in Bristol, England.



Kristiina Vuori, President
Sanford-Burnham Prebys Medical Discovery Institute

Dr. Kristiina Vuori is president of Sanford Burnham Prebys Medical Discovery Institute (SBP) and professor and Pauline & Stanley Foster Presidential Chair. She earned her M.D. and Ph.D. degrees at University of Oulu, Finland, received postdoctoral training at SBP, and was appointed to the faculty in 1996. She served as director of the Institute's NCI-designated cancer center in 2005-2013, and she has been president of SBP since 2010. Vuori was selected PEW Scholar in 1997, elected to the National Academy of Inventors in 2014, and is an investigator of a Stand Up To Cancer Dream Team. She serves or has served on boards of directors for the American Association for Cancer Research, California Institute for Regenerative Medicine, California Breast Cancer Research Program, and WebMD. She is co-founder of three biotechnology companies, and her research focuses on cancer metastasis. Presently, one approved drug and five therapies for cancer in Phase III trials stem from the work of SBP scientists.

DOUBLE DIAMOND SPONSOR



Stands For Opportunity

DIAMOND SPONSORS



EVENT RECEPTION SPONSOR



PLATINUM SPONSOR



GOLD SPONSORS



Judy Genshaft & Steve Greenbaum



— speed - innovation - solutions —





HARNESSING NANOTECHNOLOGY
FOR BIOMEDICAL APPLICATIONS



College of Engineering



Center of Excellence for Aging and Brain Repair



Department of Neurosurgery and Brain Repair



SILVER SPONSORS



City of New Orleans
Mosquito, Termite & Rodent
Control Board



College of Pharmacy



Morsani College of Medicine



• S A V E T H E D A T E •

FLORIDA INVENTORS HALL OF FAME Third Annual Induction Ceremony and Gala

September 16, 2016



TWENTY YEARS AGO, THE INFRASTRUCTURE WAS JUST BEING PUT IN PLACE.

TODAY, THE CORRIDOR IS A REGION ON A MISSION AND THE DESTINATION IS IN SIGHT.

We are moving full speed ahead to grow as a high tech hub thanks to a partnership between three world-class universities – the University of Central Florida, the University of South Florida and the University of Florida – and local economic development organizations, CareerSource boards, state colleges, high tech industry leaders and others that have grown our 23-county region.

The past has led to great achievements ... nearly \$1.12 billion in economic impact and more than 200 patents from more than 1,350 research projects as part of The Corridor's Matching Grants Research Program. The path ahead is even more promising. Watch us grow!

THE FLORIDA HIGH TECH
CORRIDOR

WWW.FLORIDAHIGHTECH.COM



THANK YOU



Bill Green, Home Shopping Network (HSN)

All Children's Hospital

California Institute of Technology

Edison & Ford Winter Estates

Florida Academy of Sciences

Jesse Panuccio, Florida Department of Economic Opportunity

Florida Institute for Human & Machine Cognition

Florida State University

Geoffrey's Floral & Event Design

Patricia Fernandez, InterContinental Tampa

Doug Jaureguy as "Henry Ford"

Museum of Science and Industry (MOSI), Tampa

Thomas Toner, Shumaker, Loop & Kendrick

Valencia Martin Wallace and the United States Patent and Trademark Office

University of Florida

USF Innovative Education, Media Innovation Team

Jill VanderKam, CFP, VALIC Financial Advisors

VGTI Florida

WUSF and intellisMEDIA

Ellen Andrews
Holly Behrend
Randy Berridge
Aimee Blodgett
Vickie Chachere
Melissa Clark
Steve Clark
Judi Dorn
Hal Dunn
Patty Gamble
Arlene Garrison
Judy Genshaft
Christine Gitch
Lauren Golin

Melissa Hamley
Rhonda Hendrix
Diane Johnston
Keara Leach
Steve Long
Judy Lowry
Tina Lucas
Kim Macuare
Allison Madden
Lauren Maradei
Shari Martinez
Valerie McDevitt
Mark McLaughlin
Arthur Molella
Laurie O'Brien

Autumn Pandolfo
Johnny Prugh
Jan Resch
Monica Richter
Bridgette Rivera
Cyndy Sanberg
Mercedes Santiago
Sudeep Sarkar
Rick Skinner
Peter Trakas
April Turley
Harry Van Loveren
Mark Walsh
Jack Wilkins

Music by:

Alejandro Arenas and LaRue Nickelson, USF School of Music

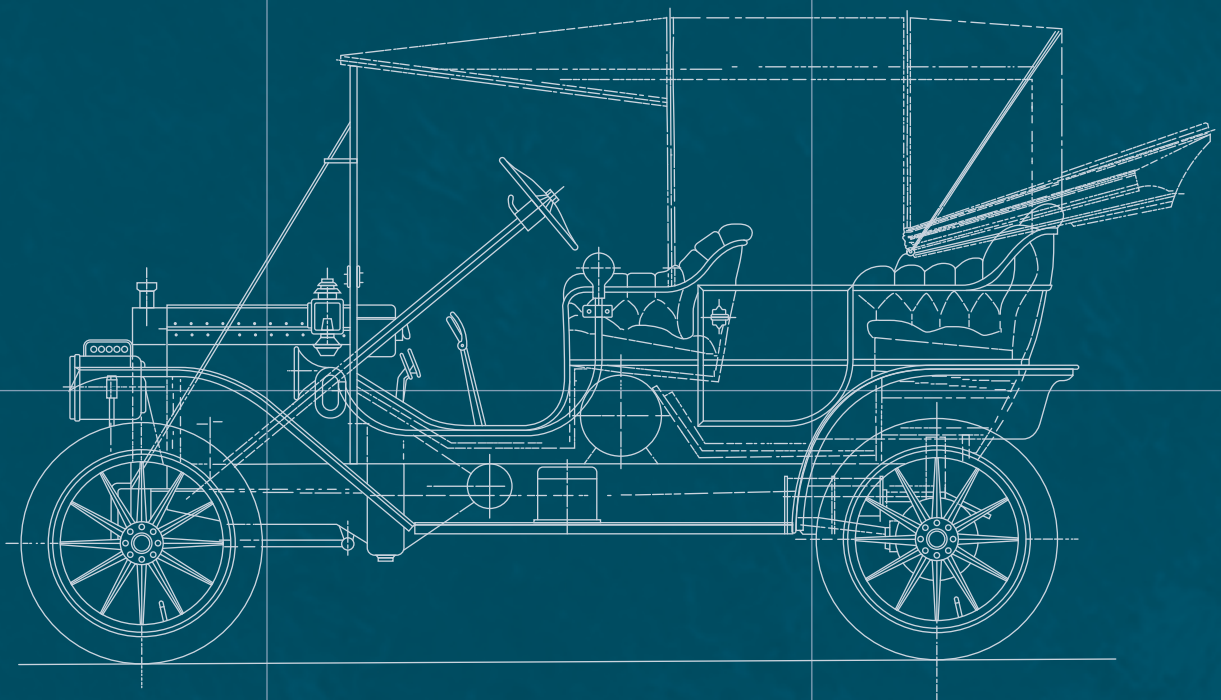

**“THE HUMAN MIND IS A CHANNEL THROUGH
WHICH THINGS-TO-BE
ARE COMING INTO THE REALM OF
THINGS-THAT-ARE.”**

HENRY FORD

**FLORIDA INVENTORS HALL OF FAME
AT THE UNIVERSITY OF SOUTH FLORIDA
HOLLY BEHREND, PROGRAM COORDINATOR
3702 SPECTRUM BOULEVARD, SUITE 165
TAMPA, FL 33612-9445**

(813) 974-1101

**INFO@FLORIDAINVENTS.ORG
WWW.FLORIDAINVENTS.ORG**